

MEQYC-50D series

ROD ELECTRIC CYLINDER - BALL SCREW DRIVE (WITH MOTOR)

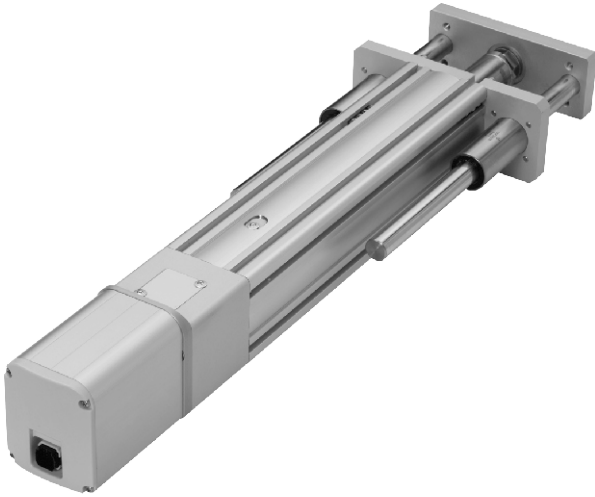

Mindman



Specification

Model	MEQYC-50D	
Repeatability (mm)	±0.01	
Ball screw lead (mm)	5	10
Maximum speed (mm/s) ^{※1}	250	500
Maximum payload	Horizontal(kg)	30
	Vertical (kg)	15
Rated thrust (N)	565	283
Stroke / pitch (mm) ^{※2}	50~300 / 50 Pitch	
Motor dimension (mm)	□42	
Ball screw spec (mm)	C7 φ 12	
Anti-rotating accuracy (θ) ^{※3}	±0.05°	

※1. The maximum speed shown here is when software speed setting is 100%.
When the stroke is over 200mm, the run-out of the ball screw will occur.

※2. We recommend to low down the working speed under this circumstances.

※3. Anti-rotating accuracy of plate

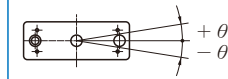

Order example of cylinder

MEQYC-50D — L05 — 100 — M — TC100 — 03 — A0001

Model

Spec.

Special order no.

Ball screw brand

Ball screw lead

Stroke

Motor position

Corresponding controller

Cable length

L T-Standard MIT

05	5 mm
10	10 mm

50~300 mm	50 mm pitch
-----------	-------------

M	Built-in
BM	On lower side
BW	On upper side

TC100
※ Please refer to 4-128.

01	1m
03	3m
05	5m
10	10m

※ Standard: 3m

Order example of controller

TC100 — 03

Controller

Cable length

TC100

Blank	No cable
01	1m
03	3m
05	5m
10	10m

※ Standard: 3m

Speed-payload curve diagram

Horizontal

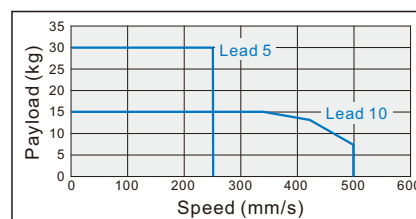

Vertical

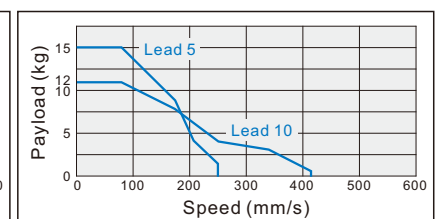

MEQYC-50D Dimensions

ROD ELECTRIC CYLINDER - BALL SCREW DRIVE (WITH MOTOR)



M Motor built-in

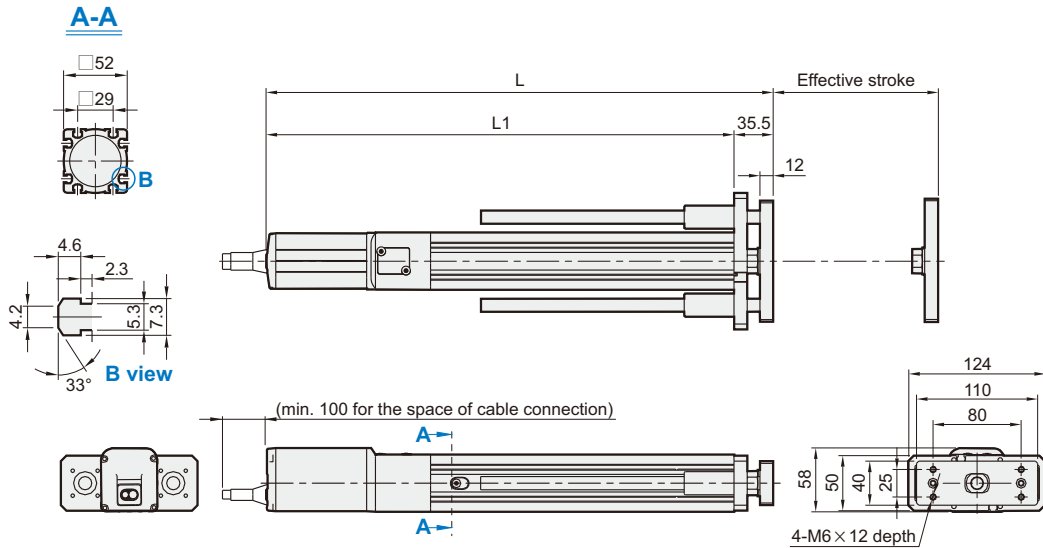

Unit: mm

Stroke	50	100	150	200	250	300
L	360.5	410.5	460.5	510.5	560.5	610.5
L1	325	375	425	475	525	575
KG	3.43	3.68	3.94	4.2	4.47	4.64

BW Motor on upper side

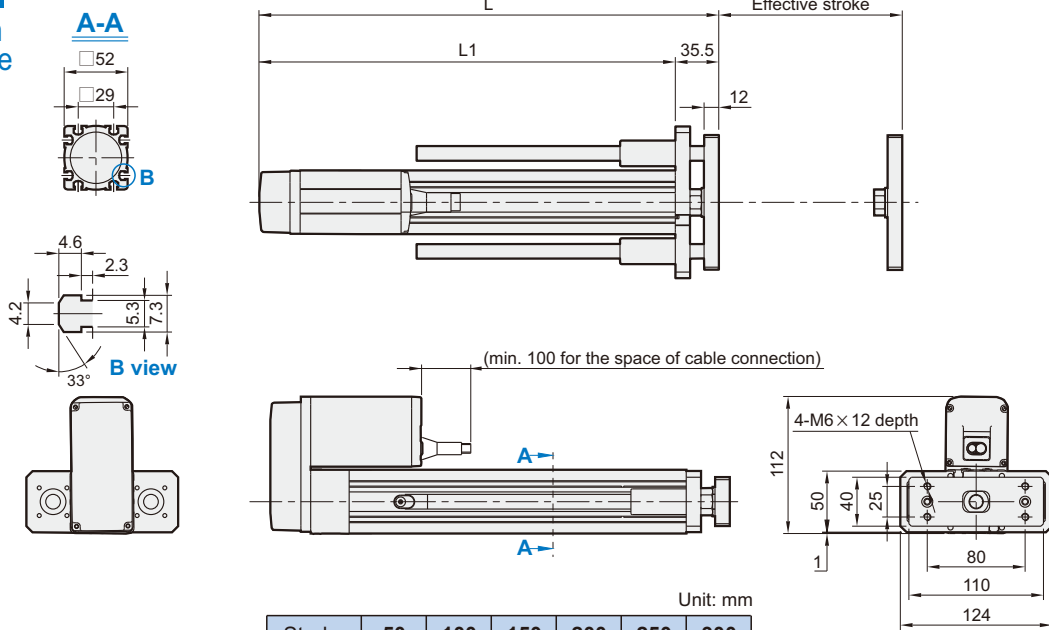

Unit: mm

Stroke	50	100	150	200	250	300
L	260.5	310.5	360.5	410.5	460.5	510.5
L1	225	275	325	375	425	475
KG	3.92	4.18	4.44	4.7	4.97	5.14

MEQYC-50D Dimensions

ROD ELECTRIC CYLINDER - BALL SCREW DRIVE (WITH MOTOR)

BM

Motor on lower side

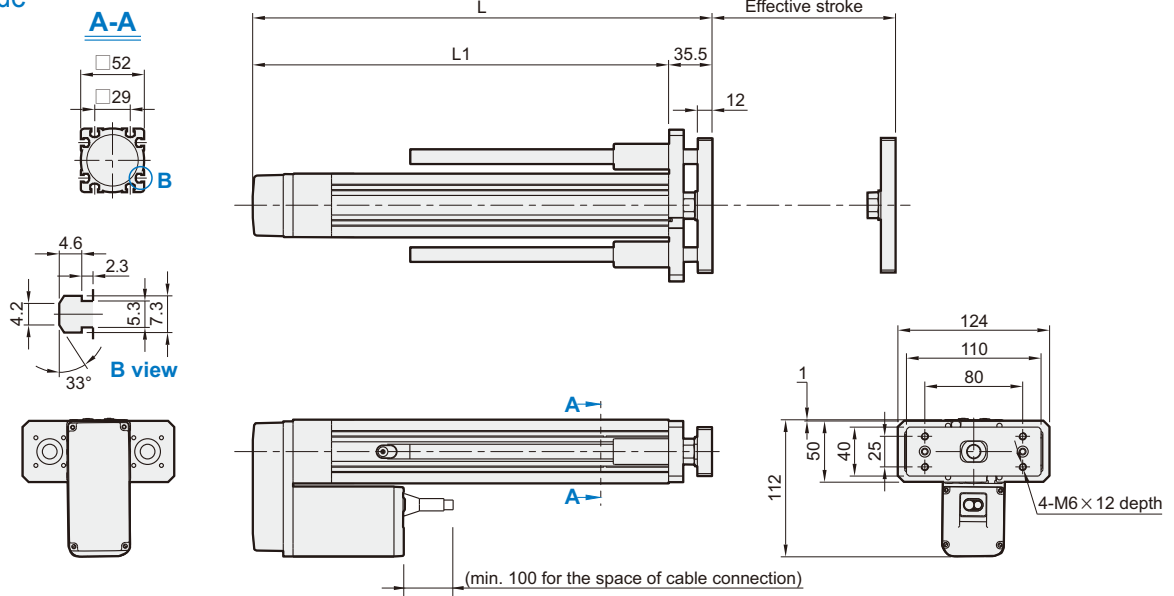

Unit: mm

Stroke	50	100	150	200	250	300
L	260.5	310.5	360.5	410.5	460.5	510.5
L1	225	275	325	375	425	475
KG	3.92	4.18	4.44	4.7	4.97	5.14