

MEQYC-65L series

ROD ELECTRIC CYLINDER - BALL SCREW DRIVE (WITH MOTOR)



Mindman



Specification

Model	MEQYC-65L			
Repeatability (mm)	±0.01			
Ball screw lead (mm)	5	10	20	
Maximum speed (mm/s) ^{※1}	250	500	1000	
Maximum payload	Horizontal(kg)	110	88	40
	Vertical (kg)	30	20	10
Rated thrust (N)	791	395	197	
Stroke / pitch (mm) ^{※2}	50~500 / 50 Pitch			
Motor dimension (mm)	□ 56			
Ball screw spec (mm)	C7 φ 16			
Anti-rotating accuracy (θ) ^{※3}	±0.05°			

※1. The maximum speed shown here is when software speed setting is 100%.

※2. When the stroke is over 300mm, the run-out of the ball screw will occur. We recommend to low down the working speed under this circumstances.

※3. Anti-rotating accuracy of plate

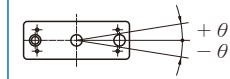

Order example of cylinder

MEQYC-65L — L05 — 100 — M — TC100 — 03 — A0001

Model	Spec.					Special order no.
Ball screw brand	Ball screw lead	Stroke	Motor position	Corresponding controller	Cable length	
L T-Standard MIT	05 5 mm 10 10 mm 20 20 mm	50~500 mm 50 mm pitch	M Built-in BM On lower side BR On right side BL On left side	TC100 ※ Please refer to 4-128.	01 1m 03 3m 05 5m 10 10m ※ Standard: 3m	

Order example of controller

TC100 — 03

Controller	Cable length	
TC100	Blank	No cable
	01	1m
	03	3m
	05	5m
	10	10m

※ Standard: 3m

Speed-payload curve diagram

Horizontal

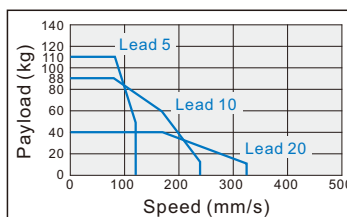

Vertical

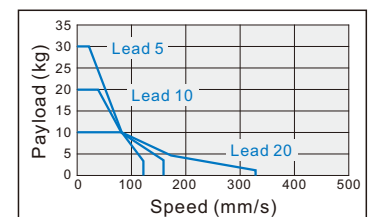

MEQYC-65L Dimensions

ROD ELECTRIC CYLINDER - BALL SCREW DRIVE (WITH MOTOR)



mindman

M

Motor built-in

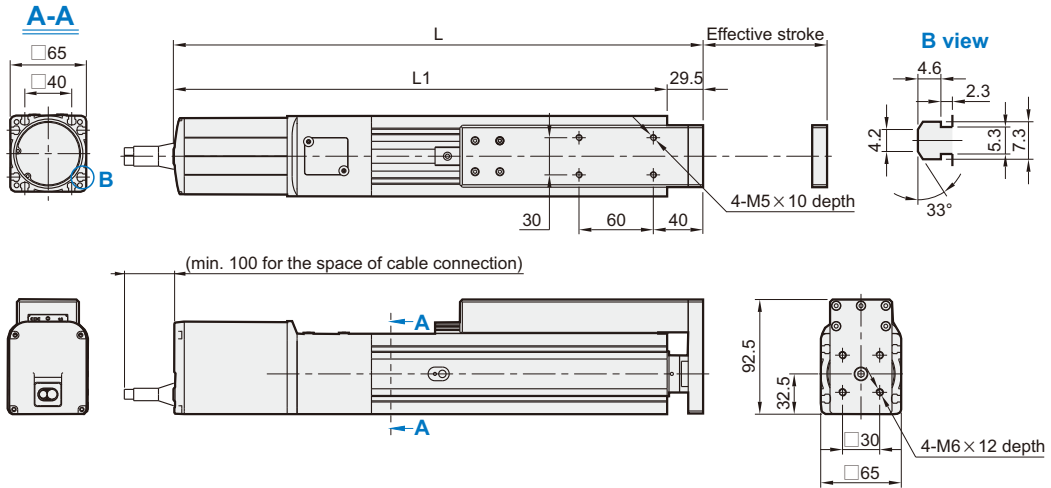

Unit: mm

Stroke	50	100	150	200	250	300	350	400	450	500
L	377.5	427.5	477.5	527.5	577.5	627.5	677.5	727.5	777.5	827.5
L1	348.5	398.5	448.5	498.5	548.5	598.5	648.5	698.5	748.5	798.5
KG	5.5	5.76	6.02	6.28	6.53	6.79	7.05	7.31	7.57	7.82

BM

Motor on lower side

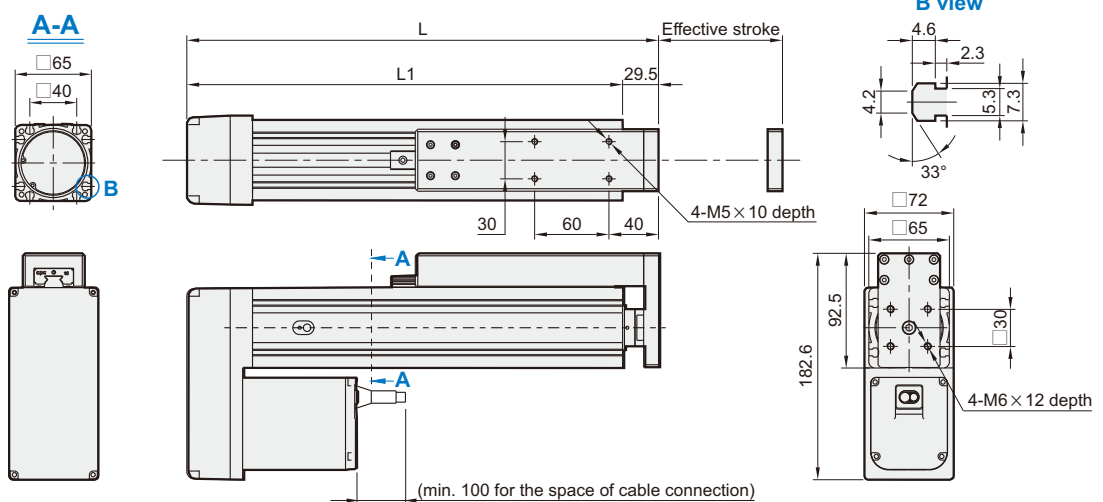

Unit: mm

Stroke	50	100	150	200	250	300	350	400	450	500
L	270.5	320.5	370.5	420.5	470.5	520.5	570.5	620.5	670.5	720.5
L1	241	291	341	391	441	491	541	591	641	691
KG	6	6.26	6.52	6.78	7.03	7.29	7.55	7.81	8.07	8.32

MEQYC-65L Dimensions

ROD ELECTRIC CYLINDER - BALL SCREW DRIVE (WITH MOTOR)



Mindman

BR

Motor on right side

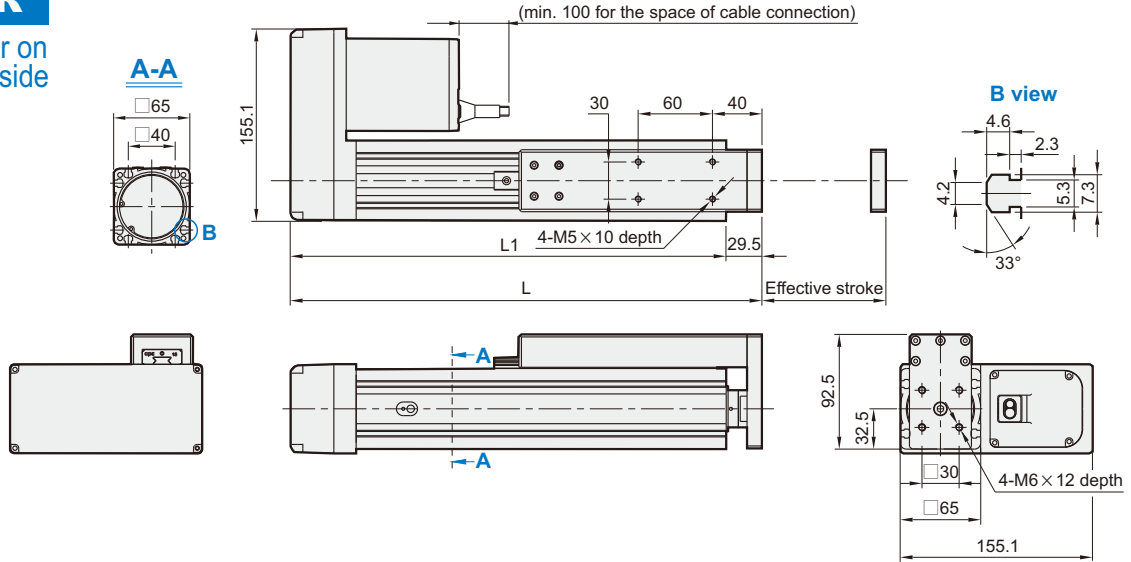

Unit: mm

Stroke	50	100	150	200	250	300	350	400	450	500
L	270.5	320.5	370.5	420.5	470.5	520.5	570.5	620.5	670.5	720.5
L1	241	291	341	391	441	491	541	591	641	691
KG	6	6.26	6.52	6.78	7.03	7.29	7.55	7.81	8.07	8.32

BL

Motor on left side

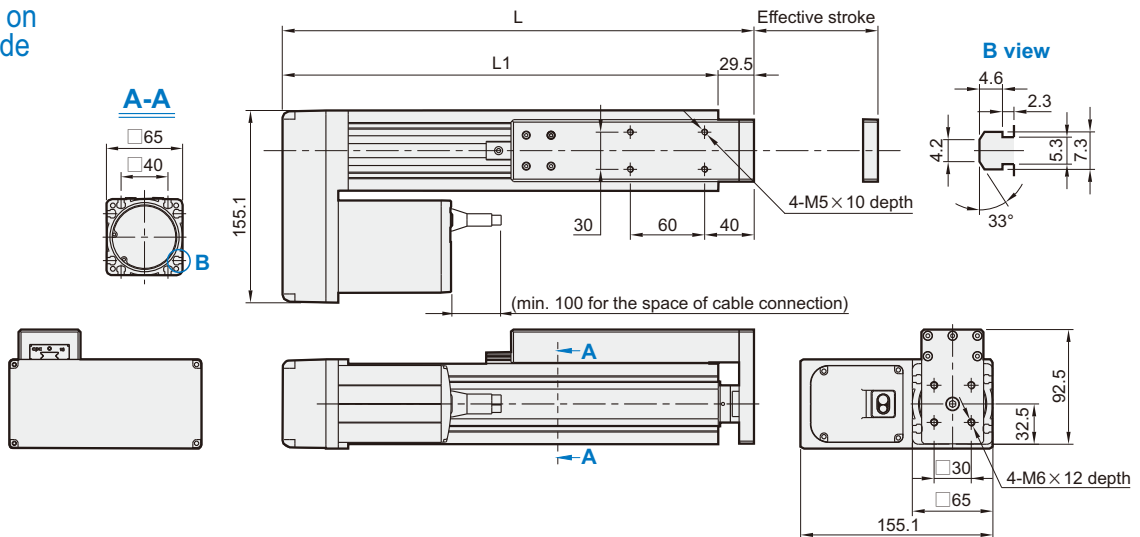

Unit: mm

Stroke	50	100	150	200	250	300	350	400	450	500
L	270.5	320.5	370.5	420.5	470.5	520.5	570.5	620.5	670.5	720.5
L1	241	291	341	391	441	491	541	591	641	691
KG	6	6.26	6.52	6.78	7.03	7.29	7.55	7.81	8.07	8.32