



### Max values for dynamic conditions.

Please refer to the following formula when combined loads are applied.

$$\frac{F_{y_A}}{F_y} + \frac{F_{z_A}}{F_z} + \frac{M_{x_A}}{M_x} + \frac{M_{y_A}}{M_y} + \frac{M_{z_A}}{M_z} \leq 1$$

※ The A letters show the calculated value.

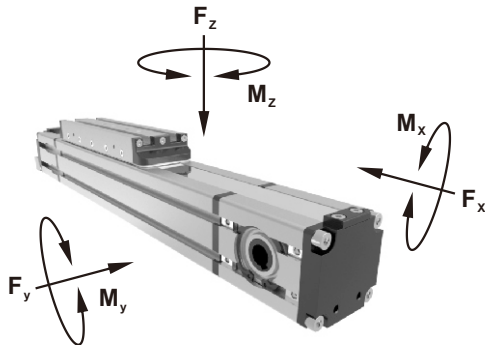

### Features

- Belt driven unit with railway integrated.
- Extruded aluminum anodized 6060 alloy, tempered stainless steel protection band.
- Carriage with sealed system to protect against pollution.

### Specification

Model		METB		
Size	mm	42	55	80
Max. speed	m/s	3	3	3
Max. stroke length	mm	6000	6000	6000
Min. stroke length	mm	100	100	100
Pulley drive ratio	mm	90	120	160
Number of teeth of pulley	mm	18	24	32
Teeth belt with steel reinforced polyurethane ATL 5 profile clearance 0, width	mm	12	16	25
Max rpm	g/min	2000	1500	1150
Base weight	Kg	1.6	4.4	6
Add for 100 mm of stroke	Kg	0.25	0.37	0.9
Max. load	Fx N	460	820	1650
	Fy N	1560	1850	4500
	Fz N	1560	1850	4500
Moments	Mx Nm	20	25	80
	My Nm	55	120	450
	Mz Nm	55	120	450
Inertia moment aluminum profile	Ix cm <sup>4</sup>	11.8	36	183
	Iy cm <sup>4</sup>	14.2	45	226
Repeatability	mm	±0.05	±0.05	±0.05
Max. radial load on input shaft	N	220	300	300
No load torque	Nm	>0.1	>0.5	0.9
Sensor switch (※)		RCI, RNI, RPI		

※ RCI, RNI, RPI specification, please refer to page 5-7.

### Order example

**METB - 42 - 0100 - F08 L - EM2A**

Model	Size (mm)	Stroke	Shaft versions	Male shaft	Accessory
<b>METB</b> Female shaft	<b>42</b> 42×42	100-6000 mm ( four codes )	Size   Type   φ   Part No. 42   Female shaft   8   <b>F08</b> 42   Male shaft   12   <b>M12</b> 42   Double male shaft   12   <b>D12</b>	<b>L</b> Left shaft <b>R</b> Right shaft	<b>E</b> End cap mounting <b>M</b> <sup>※1</sup> Mid section mounting <b>A</b> <sup>※2</sup> Limit switch adapters
Male shaft	<b>55</b> 55×55	※ Minimum stroke unit 1mm.	55   Female shaft   8   <b>F08</b> 55   Male shaft   16   <b>M16</b> 55   Double male shaft   16   <b>D16</b>		※ A type only for size 80. ※1. Number of accessory Blank   1 set (2 pcs) <b>2</b>   2 set (4 pcs) <b>n</b>   "n" set (n×2 pcs)
Double male shaft	<b>80</b> 80×80		80   Female shaft   19   <b>F19</b> 80   Male shaft   19   <b>M19</b> 80   Double male shaft   19   <b>D19</b>		※2. Number of accessory Blank   1 pc <b>2</b>   2 pcs <b>n</b>   "n" pcs

### End supported top load

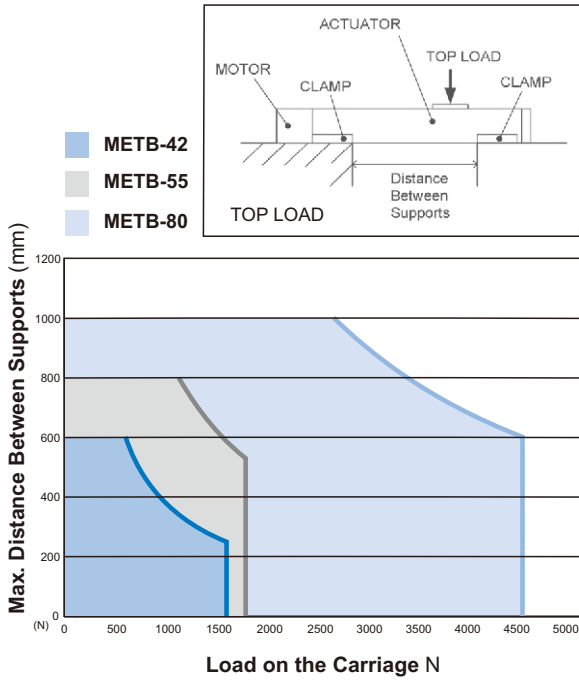

### End supported side load

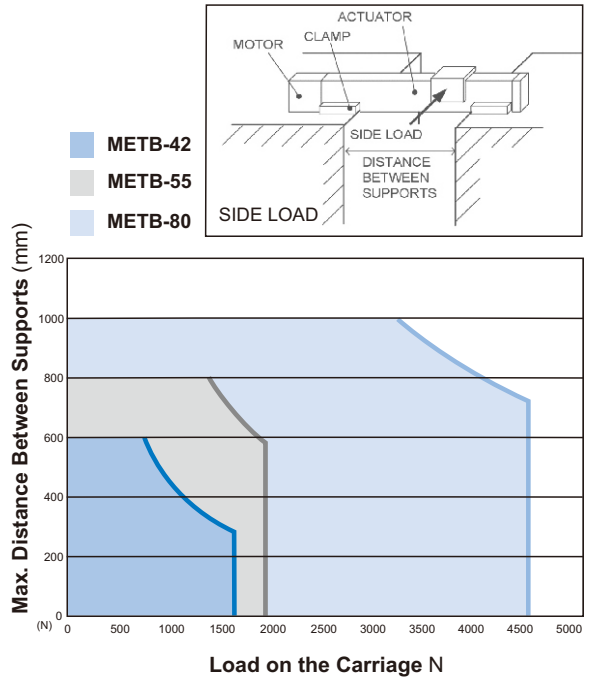

### Cantilevered top load

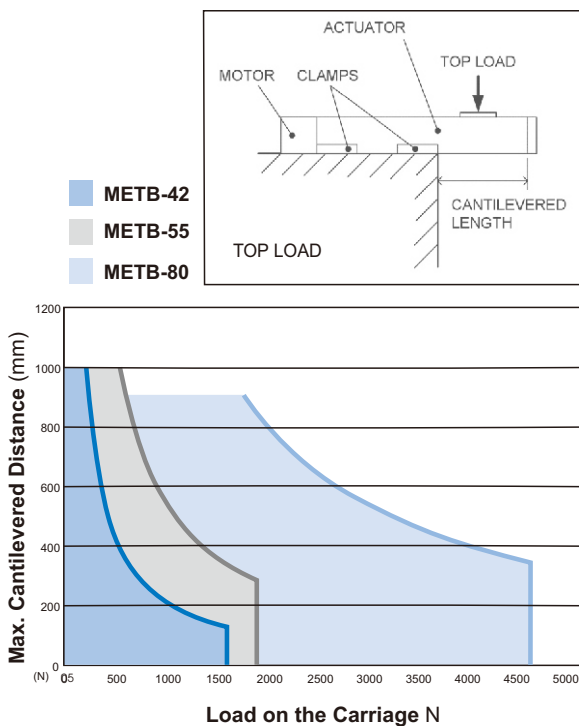

### Cantilevered side load

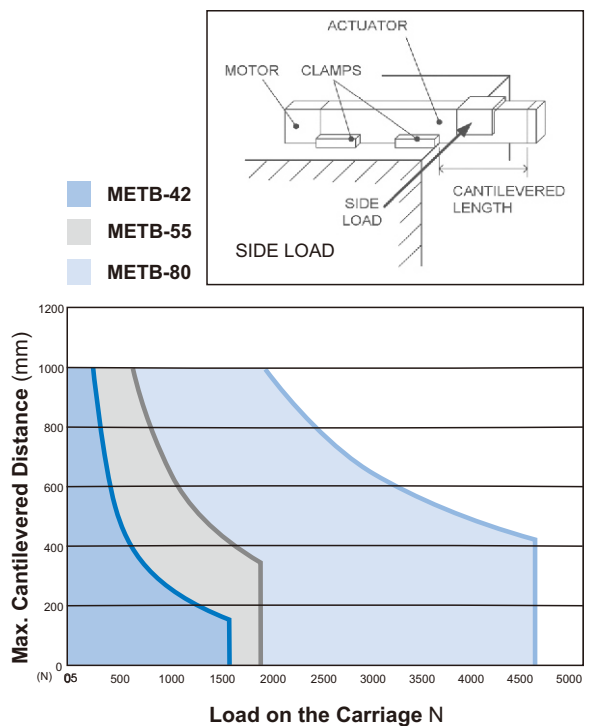

## SLIDER ELECTRIC CYLINDER - BELT DRIVEN

42,  55

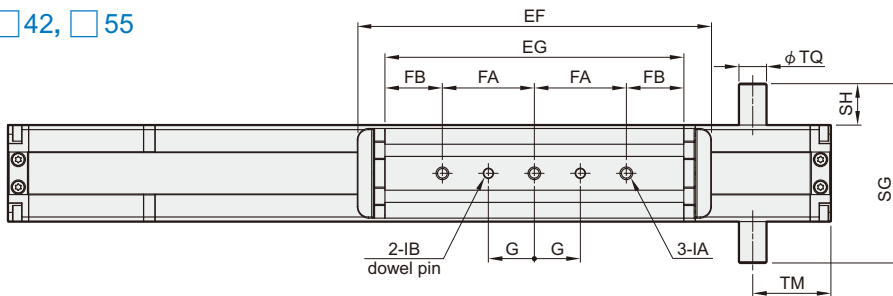

80

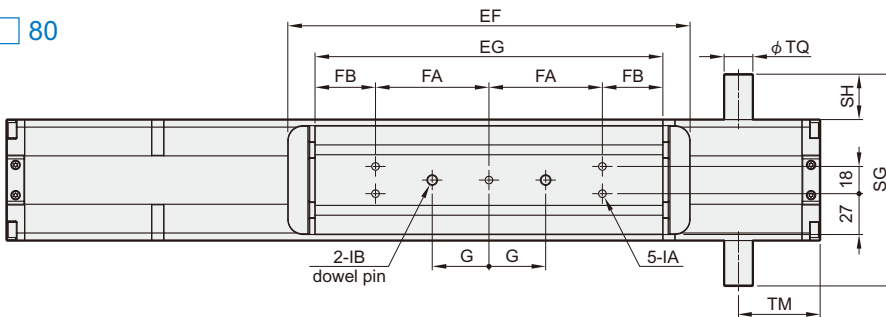

### Groove position

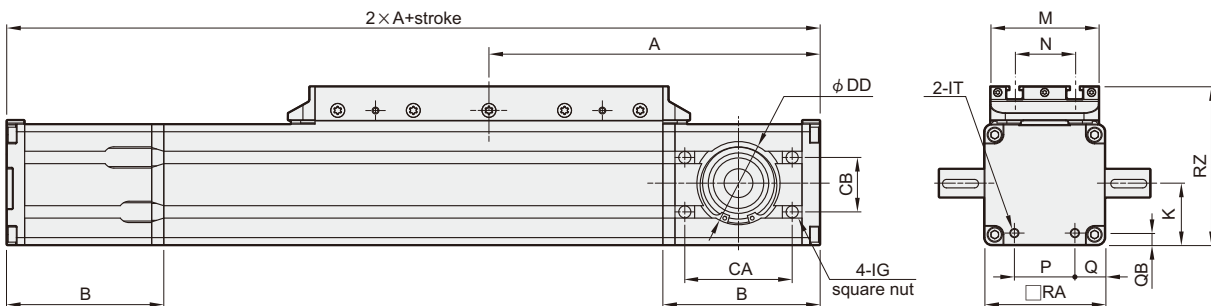
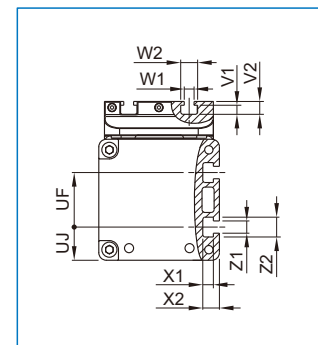

### Shaft versions

Female shaft

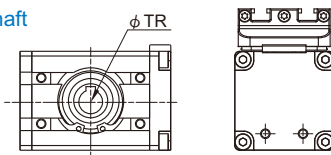

Double male shaft

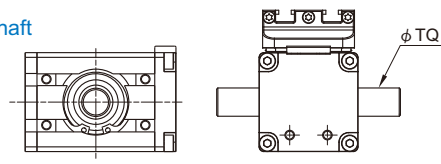

Single male shaft:  
side right

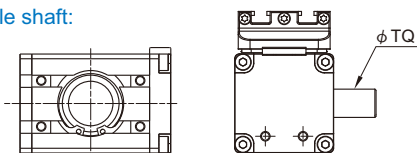

Single male shaft:  
side left

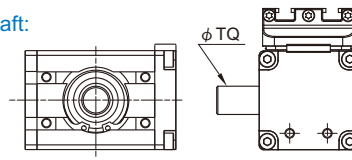

Code Tube I.D.	A	B	CA	CB	DD	EF	EG	FA	FB	G	IA	IB	IG
42	129	64	max. 42	19.5	$\phi 28 \times H7 \times 1.5$ depth	154	130	40	25	20	$M5 \times 0.8 \times 5$ depth	$\phi 4 \times H7 \times 5$ depth	$M5 \times 0.8$ DIN 562
55	166	88	max. 55	22	$\phi 32 \times H7 \times 1.5$ depth	190	150	55	20	30	$M5 \times 0.8 \times 7.5$ depth	$\phi 5 \times H7 \times 5$ depth	$M5 \times 0.8$ DIN 562
80	219	104	max. 71	35.9	$\phi 55 \times H7 \times 1.5$ depth	266	230	75	40	37.5	$M6 \times 1.0 \times 10$ depth	$\phi 6 \times H7 \times 10$ depth	$M8 \times 1.25$ DIN 562

Code Tube I.D.	IT	K	M	N	P	Q	QB	RA	RZ	SG	SH	TM	TQ	TR	UF	UJ	V1	V2	W1	W2	X1	X2	Z1	Z2
42	$M4 \times 7$ depth	21	39	20	16	13	7	42	60	82	20	34	12	8	19.5	11	3.2	4.9	5.3	8.6	3.2	4.9	5.3	8.6
55	$M5 \times 7$ depth	25	50	28	23	16	8	55	76	92	18.5	48.5	16	8	22	16.5	4.2	6.2	5.2	8.4	4.3	6.3	5.3	8.6
80	$M6 \times 8$ depth	41	72	40	40	20	8	80	105	140	30	54	19	19	36	22	6	8.5	6.5	11.2	7	11	8.2	13.2

### End cap mounting

(2pcs/set)

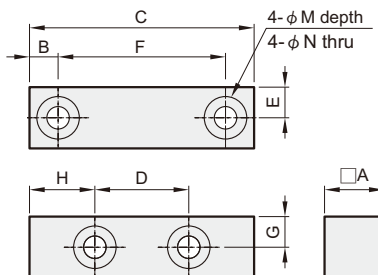

Code Size	A	B	C	D	E	F	G	H	M	N	Order number
METB-42	14	5	42	16	7	32	7	13	8×4.4 depth	4.5	ETB42-1
METB-55	15	7	55	23	7.5	41	7	16	10×5 depth	5.5	ETB55-1
METB-80	16	8	80	40	8	64	8	20	11×6 depth	6.6	ETB80-1

### Mid section mounting

(2pcs/set)

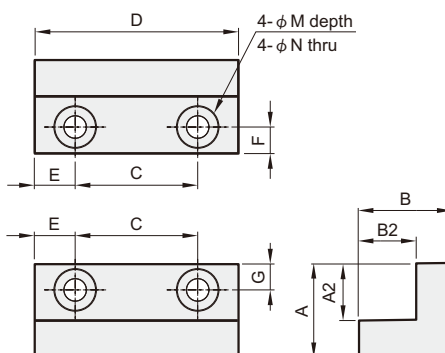

Code Size	A	A2	B	B2	C	D	E	F	G	M	N	Order number
METB-42	17	12	17	12	25	40	7.5	6	6	10×3.5 depth	5.5	ETB42-2
METB-55	23	14	23	14	30	50	10	6.5	6.5	10×5.5 depth	5.5	ETB55-2
METB-80	32	19	34	21	40	60	10	8	10	15×8.6 depth	9	ETB80-2

### Installation of sensor switch

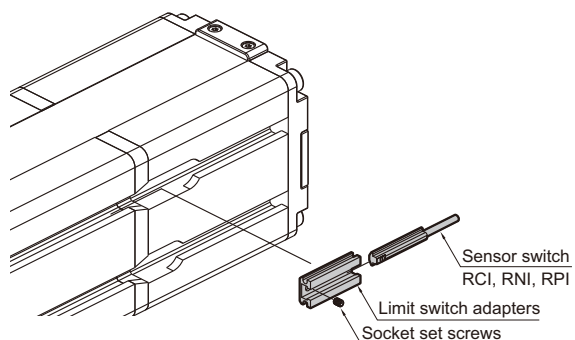

### Limit switch adapters

ETB80-3 (Only for size 80)

